



joloda  
hydraroll

LIGHTENING LOADS

WORKING IN  
PARTNERSHIP WITH



rollerbed systems:  
block pallets

modular  
systems:  
pallets

# introduction

## Modular Rollerbed Systems

Joloda Hydraroll's range of modular roller systems are a diverse and innovative solution. Our systems are proven to make your logistical processes as easy and dynamic as possible to save you time and money to make your business more efficient and profitable.

Our innovative solutions have seen us specialise in the entire logistical process, from moving cargo around factories, warehouses and airports, to moving loads through docking bays, into trailers such as trucks and vans.

Our modular roller systems have a variety of different applications. We've assembled a suite of different brochures to help you understand how to streamline your logistics processes and create the ideal solution to your loading problems.



AIR CARGO



WAREHOUSES



VANS



Our modular rollerbed system enables any standard trailer, van or warehouse to be converted into a special unit with a pneumatic rise and fall rollerbed for handling all kinds of block pallets.

The system consists of multiple lightweight aluminium frames that are interconnected and equipped with lanes of rollertrack. Depending on the trailer length, frames are fixed on top of the existing floor.

The average time to install a system and convert a trailer is between 8-12 working hours for two people, depending on system configuration.

# contents

Installation Process	5	Schematic Drawings	12
Basics of Design	6	Installations	14
Rollertrack Types	7	Videos	16
Platform Fixings	8	Why Choose Us?	17
System Controls	9	About Us	18
Autodown Function	10	Global Leaders	19
Pallet Stops/Ramps	11	Let's Chat	20

# installation 'process'



# basics of design

## Modular Rollerbed System Design

The design of the frames is based on aluminium floorboards, which feature pneumatic rise and fall rollertrack modules. No welding is needed to make a frame.

The frames are supplied pre-assembled and ready for installation. The frames come in lengths of around 3,200mm. Each frame contains four or six lanes of rollertracks. The design of the system is based on a continuous airbag over the full length of the system.

The closing plates on the front sides of the frames are screwed in, whilst the last plate at the door side of the trailer is equipped with two pallet stops. When the pre-mounted frames are in place on the trailer floor, they are secured using special clamping brackets.

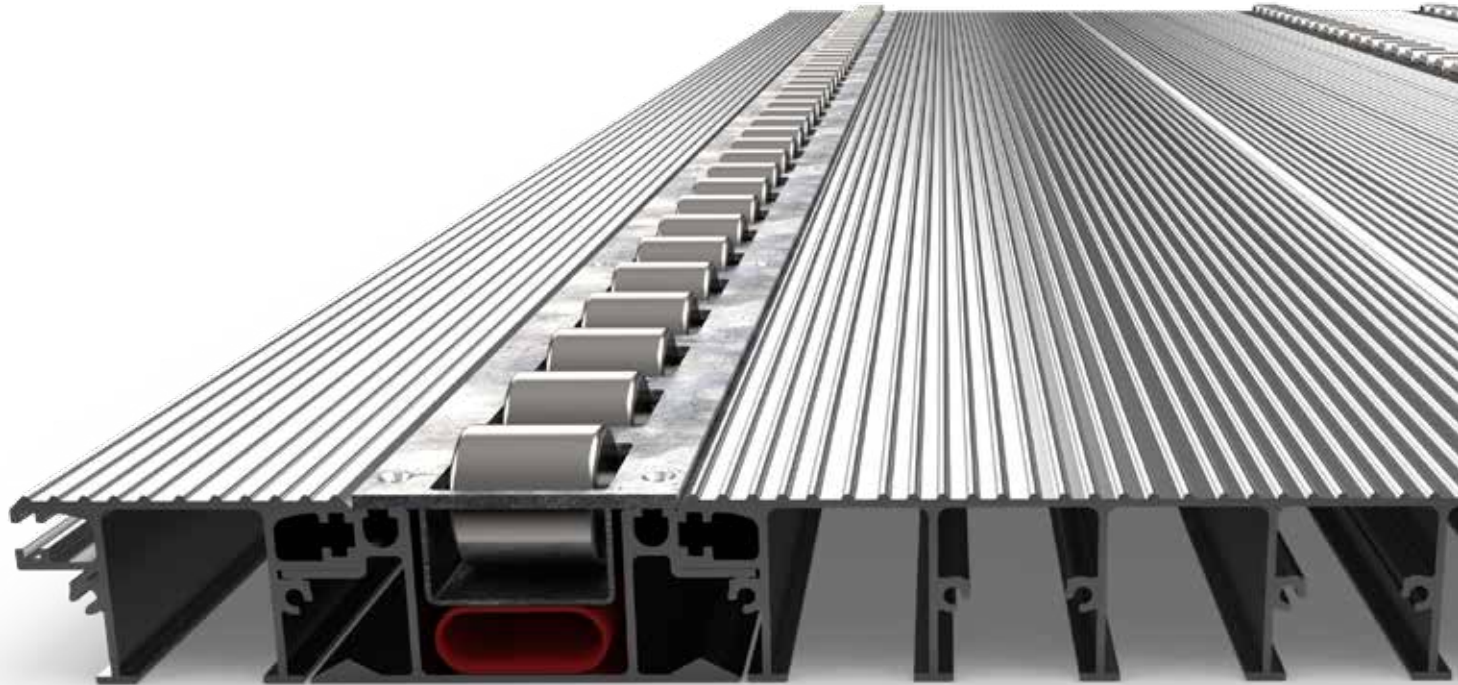

# rollertrack types

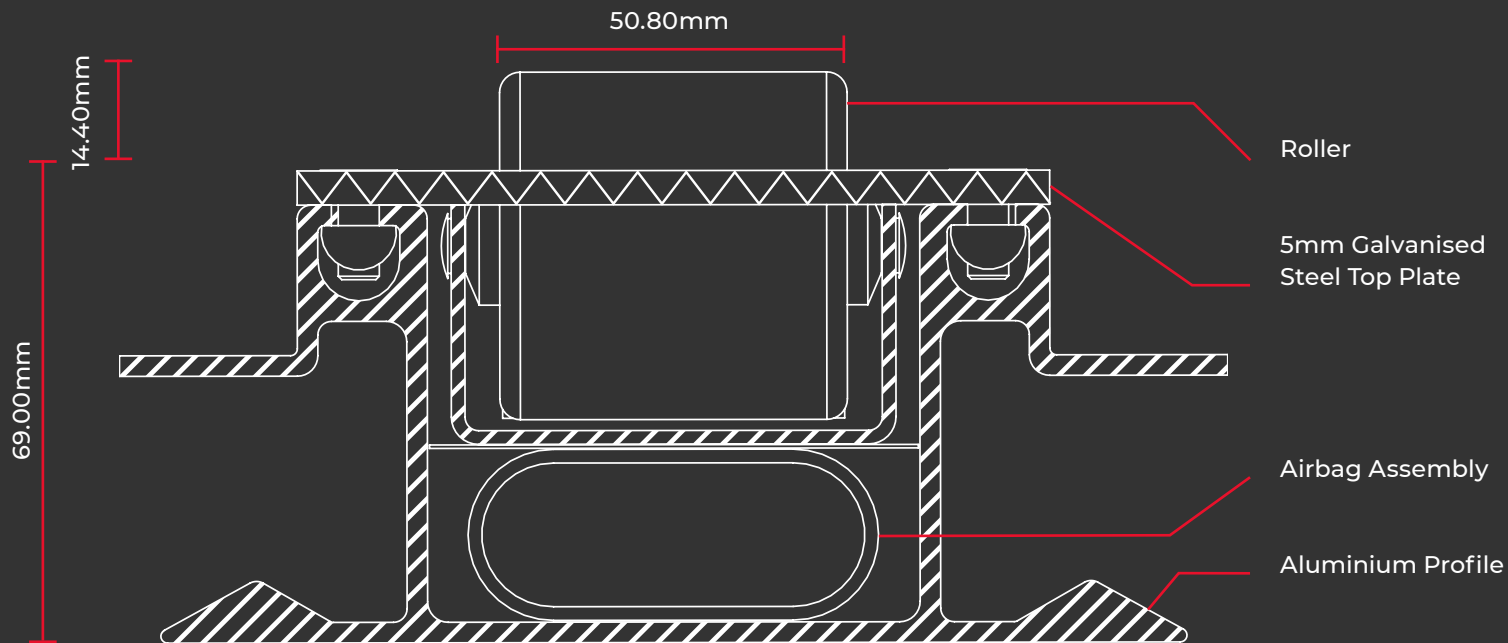

## MK4 Single Rollertrack

The modular rollerbed system for block pallets is configured with our MK4-type single rollertrack module (which features a 50mm-wide roller) ensuring that pallets have sufficient support underneath.

As an option, our MK17-type single rollertrack module (which features a 75mm-wide roller) can handle a wider variety of different pallet types.

# platform fixings

## Frames and Fixings

The frames can be fixed to the floor of the trailer by either using clamping brackets or plastic clamping profiles.

For curtainsider or flatbed trailer applications, clamping brackets are essential to fix and secure the frame to the trailer's floor.

For box or thermal floor trailers, clamping profiles can be used to secure the frame to the trailer between either sidewall. There is no requirement to drill holes.



CLAMP FOR THERMAL FLOOR



CLAMP FOR WOODEN FLOOR



# system controls

## Manual Pneumatic Control Box

The modular rollerbed system comes with a stainless steel control panel, as standard. The control panel is fitted on the side of the trailer's chassis, near the door openings and is controlled using the pneumatic operation control valves.

## Electric Pneumatic Control Box With Pendent Controller

The system can also be specified with a handheld pendent controller, this allows the operator to control the system whilst standing next to the door opening, instead of to the side of the trailer.



STAINLESS STEEL CONTROL  
BOX UNDERNEATH TRAILER



MANUAL PNEUMATIC CONTROL  
PANEL



1. ELECTRIC PNEUMATIC  
CONTROL PANEL



2. ELECTRIC PNEUMATIC  
PENDENT CONTROLLER

# autodown function

The modular rollerbed system comes complete with an 'Autodown' safety feature; an electronic bypass valve, as standard. This is integrated into both control box types.

In the scenario that a section of rollerbed isn't lowered prior to the trailer setting off, the autodown feature will lower any raised rollers to prevent the cargo from being 'live' whilst in transit.

The electronic valve is connected to the trailer's brake light, so when the driver presses the brake pedal, it sends an electronic pulse to the control box and activates the exhaust valve. It will lower all 'live' sections when the electronic pulse is received.



1. BRAKE PEDAL DEPRESSED

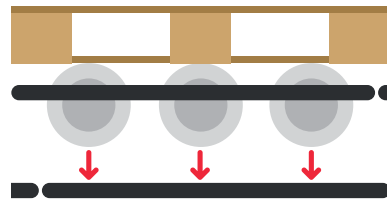

2. RAISED ROLLERTRACK

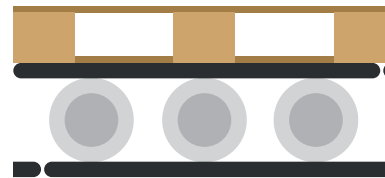

3. SECURE LOAD



4. SAFE HAULAGE

# pallet stops/ramps

Our modular rollerbed system comes complete with four integrated pallet stops, as standard. The pallet stops work as a measure, preventing cargo from rolling out of the trailer.

The system can be supplied with a small ramp for each pallet row, too. The ramp slows down the pallet at a controlled pace when being rolled towards the door opening and makes it easier for a forklift to lift the pallet off the frames.



INTEGRATED PALLET STOPS



PALLET RAMPS

# schematic drawings

## Four-lane system assembly

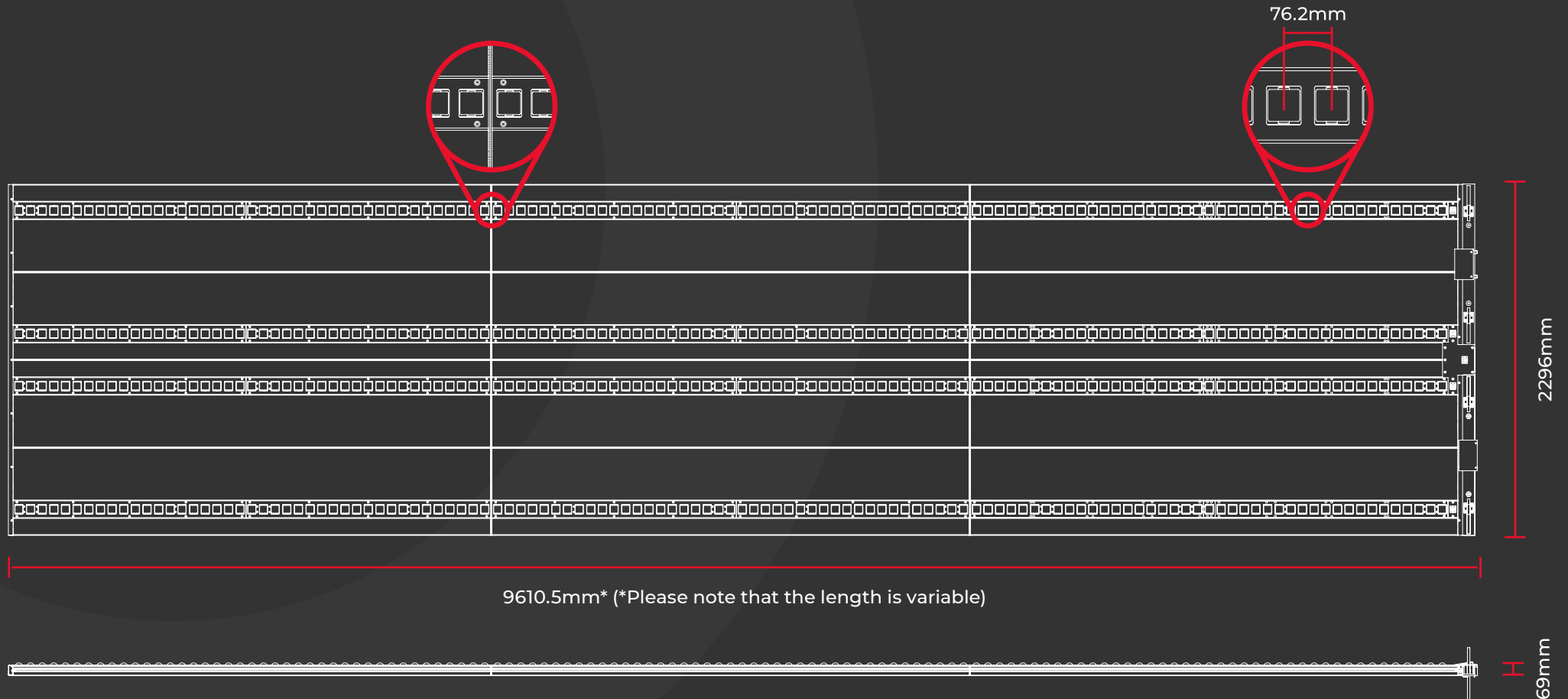

# schematic drawings

## Six-lane system assembly

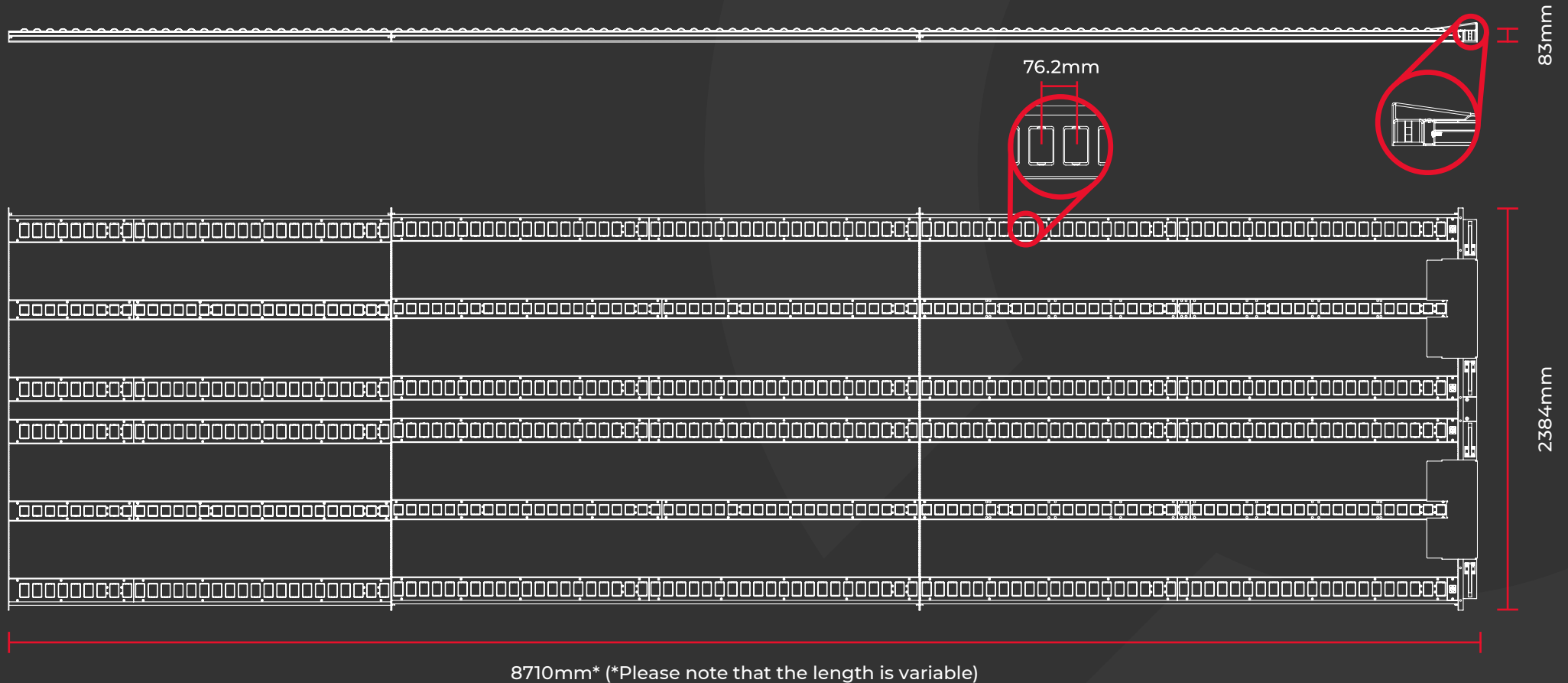





Watch now,  
scan here.

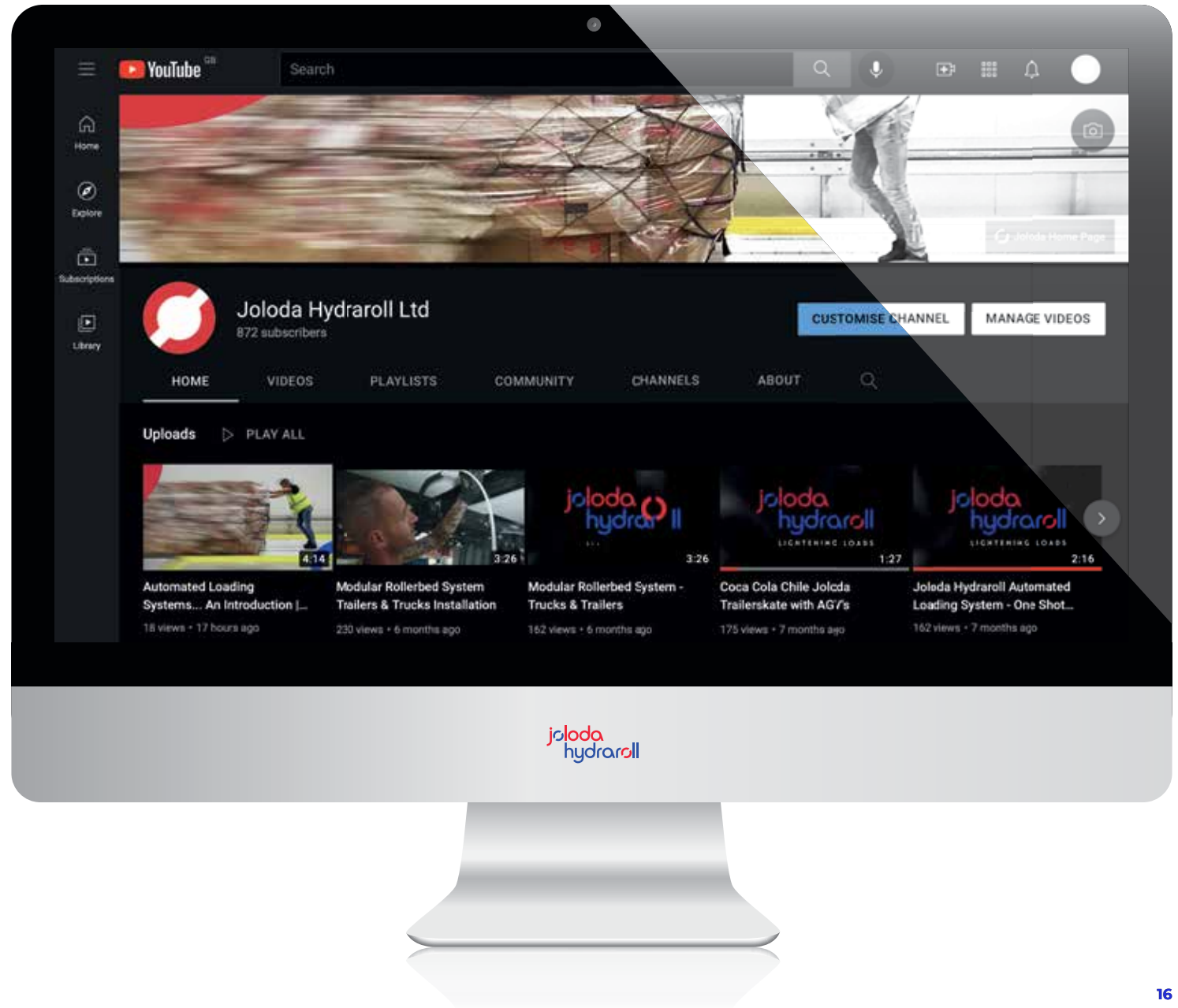



# why choose us?

We're much more than 'off-the-shelf'. We're the creators, the experts and we're here to help streamline your logistics and create the ideal loading solutions for your loading problems.



# about us

We help businesses lighten loads.  
We are highly regarded as the world's leading loading and unloading solutions provider in the logistics industry.

Over the last 60 years, we've helped thousands of businesses streamline their logistics operations to be more cost-efficient, more sustainable, and more health and safety-conscious.

We're more than 'off-the-shelf'. We're the pioneers, the creators, the experts. We design, manufacture, install, service and maintain world-class loading solutions. We can help innovate, automate and streamline your end-of-production line problems, wherever you are.

We have an experienced network of 30+ distributors that offer a helping hand to have experts in local standards.

We have installed more than 500,000 loading systems and through our extensive knowledge and expertise, we inspire change and make manual loading solutions more efficient and effective.

We are the world leaders in loading solutions, and we're here to lighten your load.



# a global leader, with local partners



**Europe**

- Belgium
- Czech Republic
- France
- Germany
- Italy
- Netherlands
- Poland
- Portugal
- Spain
- Sweden
- UK

**Asia**

- Dubai
- India
- Japan
- Korea
- Malaysia
- Saudi Arabia
- Taiwan
- Thailand
- Turkey

**Africa**

- Egypt
- South Africa

**Americas**

- Argentina
- Brazil
- Chile
- Mexico
- USA

**Oceania**

- Australia

Joloda Hydraroll

Let's Chat

# if you have any questions, please get in touch!

joloda  
hydraroll

LIGHTENING LOADS

WORKING IN  
PARTNERSHIP WITH



lightening loads around the world

[joloda.com](http://joloda.com)

**Southern States Group**

4-6 Burns Road, Altona  
VIC 3018, Australia  
+61 3 8689 7111  
[info@ssgroup.com.au](mailto:info@ssgroup.com.au)

**Joloda Hydraroll Ltd (Head Office)**

1 De Havilland Drive, Liverpool  
L24 8RN, United Kingdom  
+44 151 427 8954  
[hello@joloda.com](mailto:hello@joloda.com)

**Joloda BV (European Office)**

De Hulst 13, 5807 EW, Oostrum  
Venray, The Netherlands  
+31 478 501 059  
[sales@joloda.nl](mailto:sales@joloda.nl)

**Joloda Loading Automation (USA Office)**

PO Box 4820, Wilmington  
North Carolina, 28406, USA  
+1 910 791 2125  
[brett.murrill@loading-automation.com](mailto:brett.murrill@loading-automation.com)

**Joloda Hydraroll SAS (French Office)**

1 Cour du Havre, CS50101  
75008 Paris, France  
+ 33 7 81 41 99 00  
[jbalsemin@joloda.com](mailto:jbalsemin@joloda.com)